

## Antigen Recognition and Receptor Diversity

K.J. Goodrum  
Department of Biomedical Sciences  
2005

### Antigen-Antibody Reactions: Terms to know.

- Size of Epitope/antigenic determinant
- specific, noncovalent, reversible binding
- affinity vs. avidity
- valency, crosslinking, agglutination, precipitation
- multideterminant antigens,
- heterogeneous antibody responses
- cross reactions

### Topic Outline

- Antibody-antigen reactions
  - Linear vs. conformational determinants
  - Cross-reaction
- TcR recognition of peptide-MHC complexes, restriction by CD4 and CD8
- Recombinational mechanisms of receptor diversity
- Ig isotype switching and isotype functions

Antibodies can bind continuous (linear) structures or discontinuous portions of a folded macromolecule (conformational determinants).

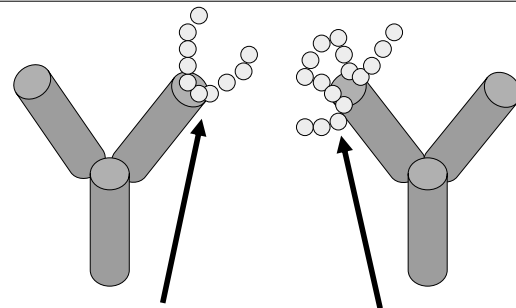

**LINEAR EPITOPE**      **DISCONTINUOUS EPITOPE**

Protein denaturation can destroy conformational determinants.

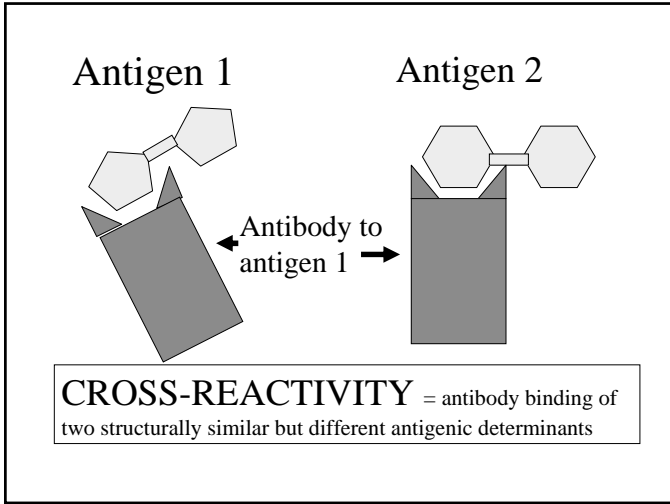

### T Cell Receptor for Antigen

- The receptor for antigen on T cells (**TcR**) is similar to Fab fragments of immunoglobulin
- TcR is composed of 2 different disulfide linked polypeptides:
  - $\alpha:\beta$  TcR or  $\gamma:\delta$  TcR
- TcR recognizes antigen as a complex of a foreign peptide bound to an MHC molecule on antigen presenting cells.

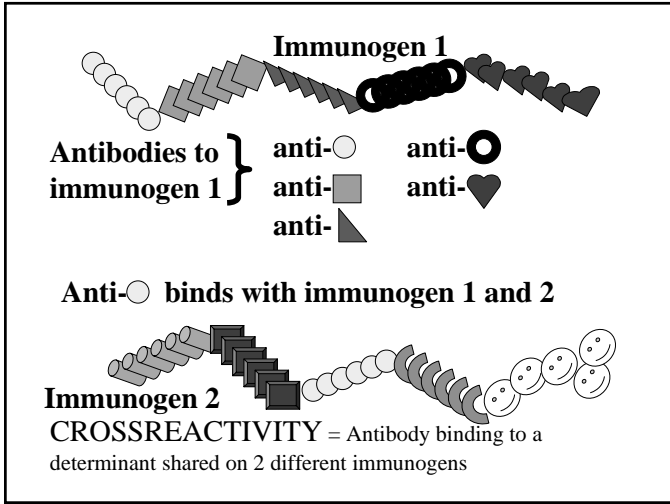

### T Cell Receptor for Antigen

- Whereas the B cell receptor (antibody) for antigen can recognize native undigested antigens of any chemical form (proteins, polysaccharides, lipids, etc.), the TcR recognizes only processed (digested) proteins as peptide-MHC complexes on the surface of antigen presenting cells.

Peptides from digested foreign proteins are bound by MHC1 or MHCII proteins on antigen-presenting cells for recognition by T cells.

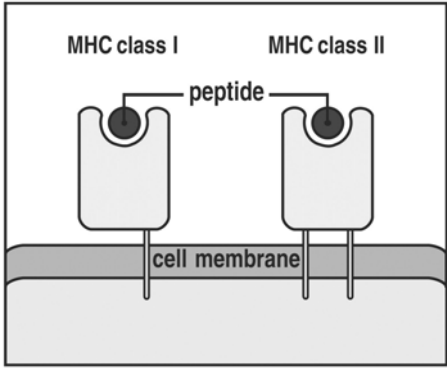
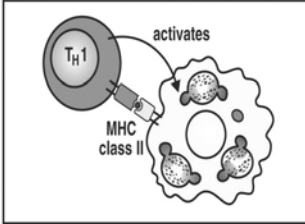

Figure 1-27 Immunobiology, 6/e. (© Garland Science 2005)

**T<sub>H</sub>1 cell recognizes complex of bacterial peptide with MHC class II and activates macrophage**



**Helper T cell recognizes complex of antigenic peptide with MHC class II and activates B cell**

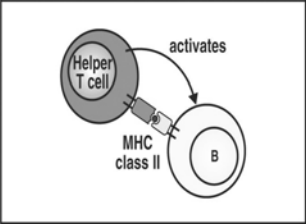

Figure 1-31 Immunobiology, 6/e. (© Garland Science 2005)

**Cytotoxic T cell recognizes complex of viral peptide with MHC class I and kills infected cell**

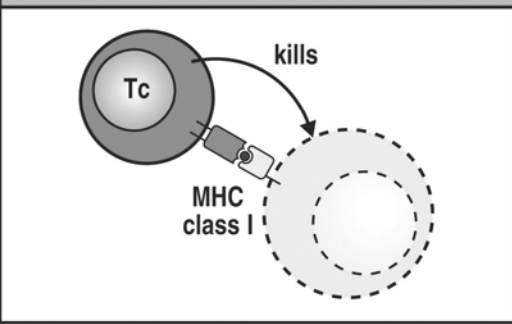
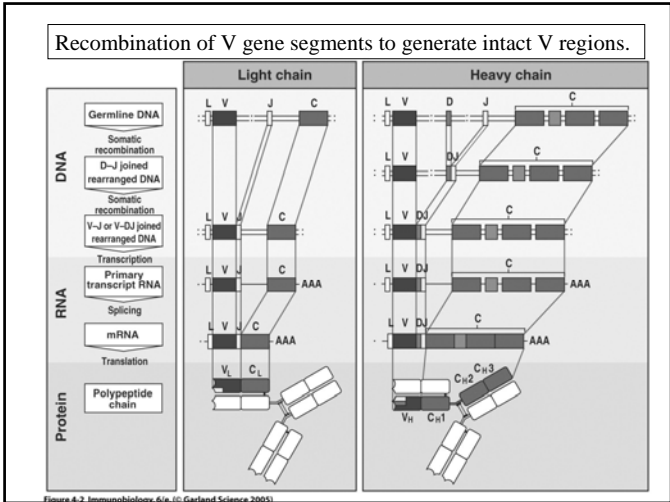
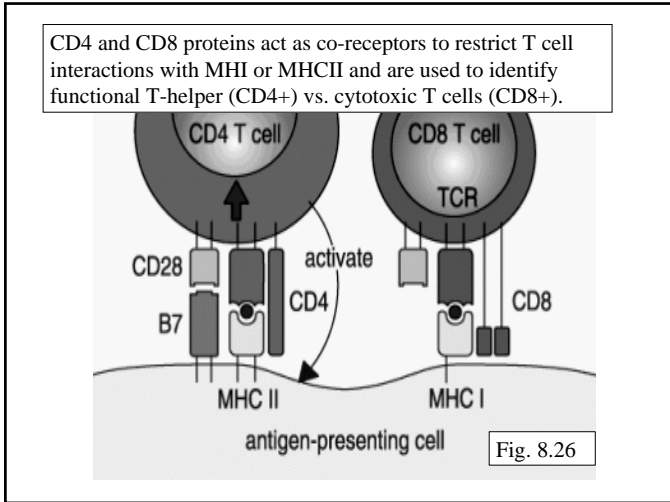

Figure 1-30 Immunobiology, 6/e. (© Garland Science 2005)

### T Cell Receptor for Antigen

- T cells express a co-receptor (CD4 or CD8) which binds to the MHC portion of the composite MHC:peptide ligand.
- Regulatory CD4-T helper cells recognize peptides complexed with Class II MHC on specialized antigen presenting cells.
- Cytotoxic CD8-T cells recognize peptides complexed with Class I MHC on any nucleated cell.



### Antigen Receptor Synthesis & Diversity

- The expression of B and T lymphocyte antigen receptors is initiated by somatic recombination of gene segments that code for the variable regions of the receptors, and diversity is generated during this process.

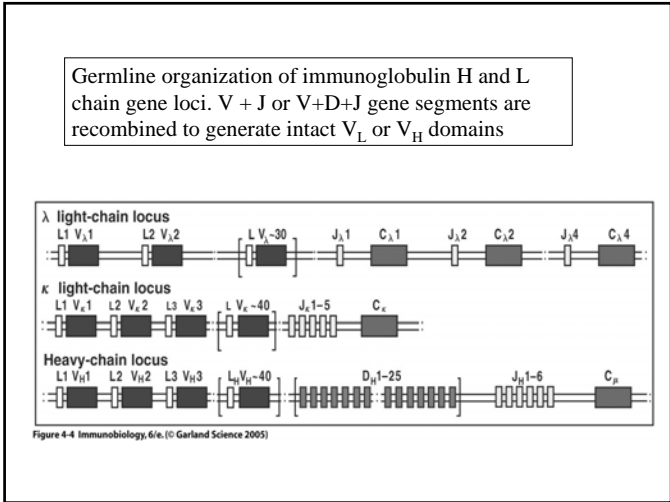

**Number of functional gene segments in human immunoglobulin loci**

Segment	Light chains		Heavy chain
	$\kappa$	$\lambda$	H
Variable (V)	40	30	40
Diversity (D)	0	0	25
Joining (J)	5	4	6

Figure 4-3 Immunobiology, 6/e. (© Garland Science 2005)

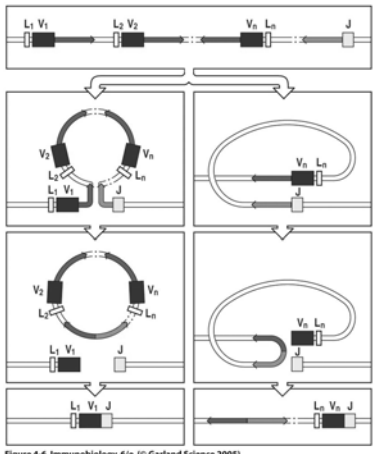

Recombinational signal sequences (RSS) flanking the V region gene segments are brought together to allow recombination to take place. Juxtaposition of RSSs results in the looping out of the intervening DNA. The joining of V and J segments creates a functional V-region exon.

Figure 4-6 Immunobiology, 6/e. (© Garland Science 2005)

### Antigen Receptor Synthesis & Diversity

- Diversity of antigen receptors is produced by:
  - Combinatorial diversity: use of different combinations of V,D,and J gene segments in different clones of lymphocytes. Different combinations of H and L chains in intact Ig.
  - Junctional diversity: changes in nucleotide sequences introduced at the junctions of V, D, and J gene segments
  - Somatic mutation of V genes in antigen-activated B cells

Functional TcR  $\alpha$ - and  $\beta$ -chain genes are generated by somatic recombination in the same way that complete Ig genes are created.

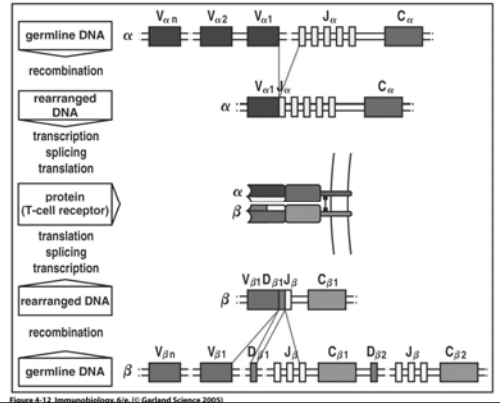
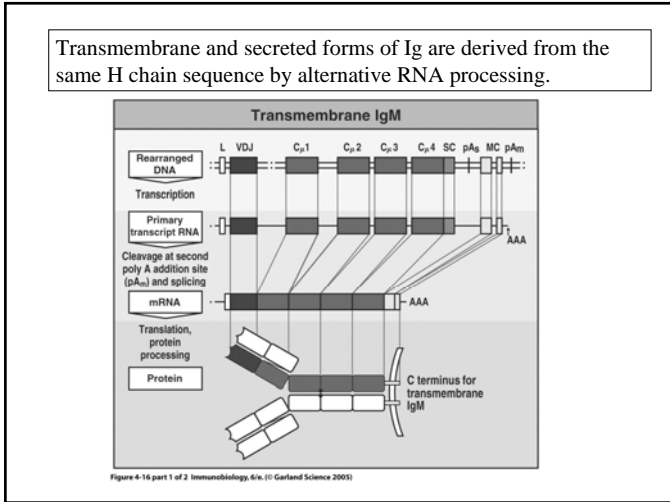
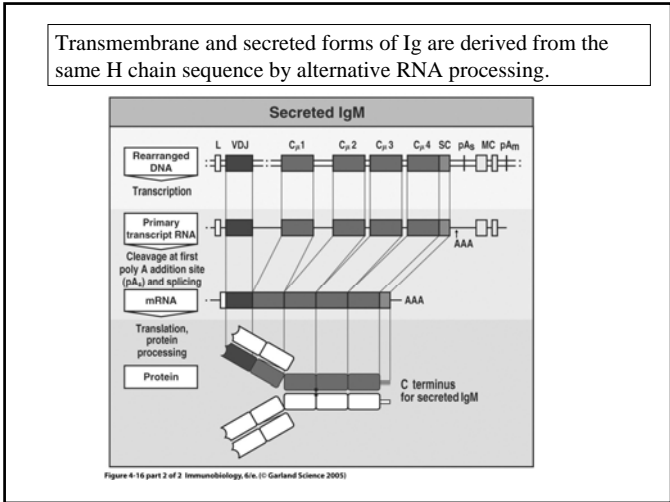
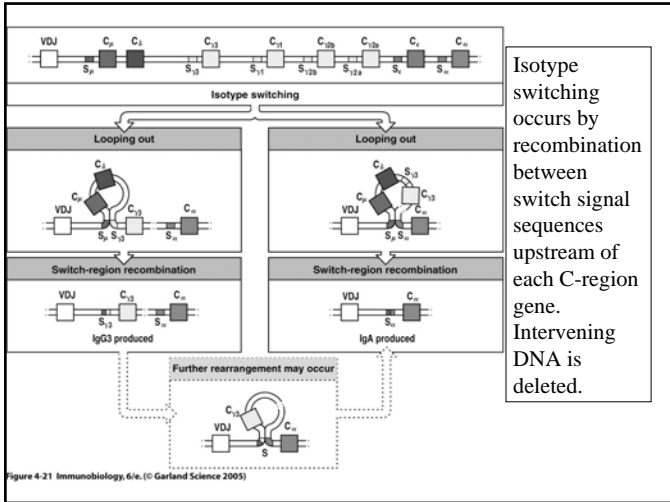

Figure 4-12 Immunobiology, 6/e. (© Garland Science 2005)



Chemical and functional properties of Ig classes.

	Immunoglobulin								
	IgG1	IgG2	IgG3	IgG4	IgM	IgA1	IgA2	IgD	IgE
Heavy chain	γ <sub>1</sub>	γ <sub>2</sub>	γ <sub>3</sub>	γ <sub>4</sub>	μ	α <sub>1</sub>	α <sub>2</sub>	δ	ε
Molecular weight (kDa)	146	146	165	146	970	160	160	184	188
Serum level (mean adult mg ml <sup>-1</sup> )	9	3	1	0.5	1.5	3.0	0.5	0.03	5 × 10 <sup>-6</sup>
Half-life in serum (days)	21	20	7	21	10	6	6	3	2
Classical pathway of complement activation	++	+	+++	-	+++	-	-	-	-
Alternative pathway of complement activation	-	-	-	-	-	+	-	-	-
Placental transfer	+++	+	++	+	-	-	-	-	-
Binding to macrophage and phagocyte Fc receptors	+	-	+	-	+	+	+	-	+
High-affinity binding to mast cells and basophils	-	-	-	-	-	-	-	-	+++
Reactivity with staphylococcal Protein A	+	+	+	+	-	-	-	-	-

Figure 4-17 Immunobiology, 6/e. (© Garland Science 2005)